



RA10 ANSI 150/300

Self-acting pressure reducers

Single seat self-acting pressure reducers for steam, water, air and other types of non-hazardous fluids (Group 2 Directive 2014/68/EU)

Equipped with balancing bellows and a large section driven plug, they allow an accurate regulation in any process condition.

Adjustment of the calibration range is extremely simple as it can be carried out with a common spanner wrench without the aid of special tools.

The "Quick-change" actuator makes the reducer setting range extremely fast even if already mounted on the plant.



EUROPEAN DIRECTIVE PRESSURE EQUIPMENT 2014/68/EU

ANSI150	ANSI300	CATEGORIA	FLUIDI
½" ÷ 2"	½" ÷ 1"	Art. 4 Par.3	Gruppo 2
2 ½" ÷ 4"	1" ½ ÷ 4"	1	Gruppo 2



14/34/EU (ATEX)



Safety Integrity Level
IEC EN 61508 - TÜV

- ◆ From 1/2" to 4" ANSI 150/300
- ◆ Modular design
- ◆ "Top Guide" construction to ensure plug stability
- ◆ "Quick-change" actuator
- ◆ Seat/plug leakage: metallic (std.) or soft PTFE (on request)
- ◆ Available in: Spheroidal cast iron, Carbon steel and Stainless steel

1. Body valve
2. Plug
3. Seat
4. Spring
5. Pressure regulation ring
6. Compensation bellows
7. "Quick-change" actuator
8. Diaphragm actuator
9. Bonnet (not in contact with the fluid)

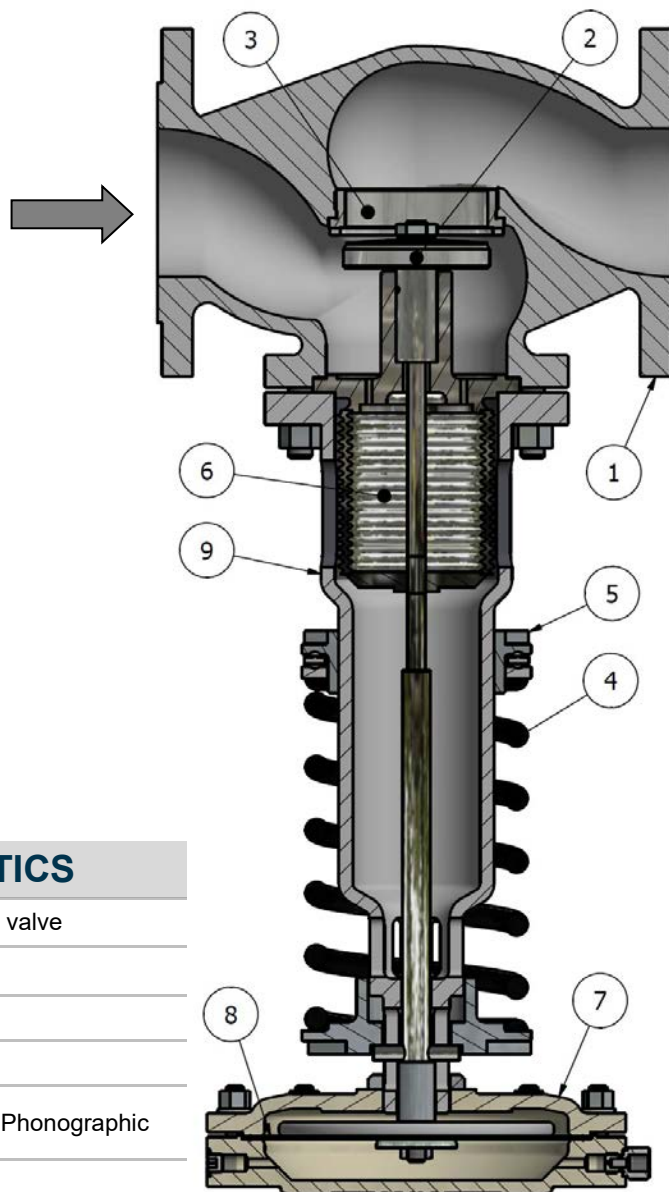

REDUCER BODY CHARACTERISTICS

Type	Top entry, single seat, globe valve
Sizes	from 1/2" to 4"
Pressure rating	ANSI Classe 150 / 300
Design std.	ANSI B16.34
Flange connection	ANSI B16.5 - Raised Face - Phonographic
Face to face dimensions	ANSI / ISA 75.08.01

REDUCER BODY PROJECT CONDITIONS

	ANSI 150	ANSI 300
Maximum upstream pressure	20 bar	25 bar
Maximum downstream pressure	See actuator	See actuator
Minimum downstream pressure	See actuator	See actuator
Maximum temperature with metallic seat	300°C	300°C
Maximum temperature with soft seat	200°C	200°C
Maximum reduction ratio	10:1	10:1

ACTUATOR PROJECT CONDITIONS

	AR265	AR205	AR150	AR120	AR100	AR085
Maximum pressure	2 bar	3 bar	10 bar	16 bar	17 bar	18 bar
Maximum temperature with EPDM diaphragm	125°C	125°C	125°C	125°C	125°C	125°C
Maximum temperature with nitrile Rubber	90°C	90°C	90°C	90°C	90°C	90°C

STD REDUCER BODY & TRIM MATERIALS COMBINATION

BODY REDUCER	BONNET	TRIM	STUD	NUTS
Carbon steel PN16/25 A216 WCC	Spheroidal graphite cast iron: EN-GJS-400-18 RT (5.3104)	Seat: ASTM A182 F316 Plug: ASTM A182 F304 Bellows: ASTM A240 Tp.316L	ASTM A193 B7	ASTM A194 H2
Carbon steel PN40 ASTM A216 WCC	Carbon steel ASTM A216 WCC	Seat: ASTM A182 F316 Plug: ASTM A182 F304 Bellows: ASTM A240 Tp.316L	ASTM A193 B7	ASTM A194 H2
Stainless steel PN16/25 A351 CF8M EN 10213-4 1.04408	Spheroidal graphite cast iron EN-GJS-400-18 RT (5.3104)	ASTM A182 F316 EN 10272 1.4529	ASTM A193 B8M	ASTM A194 8M
Stainless steel PN40 A351 CF8M EN 10213-4 1.04408	Carbon steel ASTM A216 WCC EN 10273 1.0619	ASTM A182 F316 EN 10272 1.4529	ASTM A193 B8M	ASTM A194 8M

STD ACTUATOR COMBINATION

CASING	DIAPHRAGM	TRIM	SCREWS	NUTS
Spheroidal graphite cast iron: EN-GJS-400-18 RT	EPDM (max 125°C) (others on request)	ASTM A105 + Electrolytic galvanizing Fe/Zn 8 c1A - UNI ISO 4520	Classe 8.8	ASTM A194 2H
Stainless steel A351 CF8 EN 10213-4 1.04408	EPDM (max 125°C) (others on request)	ASTM A182 F304	Classe A2-70	ASTM A194 8M

RELATION BETWEEN PRESSURE / TEMPERATURE

TEMPERATURE	ASTM A216 WCC		A351 CF8M	
	ANSI 150 (bar)	ANSI 300 (bar)	ANSI 150 (bar)	ANSI 300 (bar)
°C				
-29÷38	19.8	51.7	19.0	49,6
50	18.5	51.7	18.4	48.1
100	17.7	51.5	16.2	42.2
150	15.8	50.2	14.8	38.5
200	13.8	48.6	13.7	35.7
250	12.1	46.3	12.1	33.4
300	10.2	42.9	10.2	31.6

STANDARD PROTECTING COATING

VALVE BODY	ACTUATOR	BONNET	SPRING
<ul style="list-style-type: none"> Siliconic primer Finish with siliconic enamel RAL 9005 	<ul style="list-style-type: none"> Siliconic primer Finish with siliconic enamel RAL 9005 	Black Electrolytic zinc coatings Fe/Zn 12 BK UNI EN ISO 4042	Powder coat Polyester RAL 7032

ACTUATORS SETTING RANGE

ACTUATOR	FLOW RATE COEFFICIENTS								
	CV 6 Kv 5	CV 7,5 Kv 6,5	CV 13 Kv11	CV17 Kv 14,5	CV 35 Kv30	CV 47 Kv 40	CV 68 Kv 58	CV 90 Kv 78	CV 150 Kv 128
AR265	0.4÷1.0 bar								
AR205	0.9÷1.8 bar			0.9÷2 bar			0.9÷2.6 bar		
AR150	1.7÷3 bar			1.9÷5 bar			2.5÷8.5 bar		
AR120	2.8÷5 bar			4.5÷8.5 bar			4.5÷11.5 bar		
AR100	4.8÷7 bar			8÷15 bar			11÷15 bar		
AR085	7.8÷15 bar			///			///		

FLOW RATE COEFFICIENTS - SEAT DIAMETER

CV	Kv	Seat diameter Inch (mm)	Valve size							
			½"	¾"	1"	1" ½	2"	2" ½	3"	4"
6	5	0.8 (20)	■	—	—	—	—	—	—	—
7,5	6,5	0.8 (20)	—	■	□	□	□	□	□	□
13	11	1.0 (25)	—	—	■	□	□	□	□	□
17	14,5	1.0 (25)	—	—	—	□	□	□	□	□
35	30	1.8 (45)	—	—	—	■	—	—	—	—
47	40	1.8 (45)	—	—	—	—	■	□	□	□
68	58	2.5 (64)	—	—	—	—	—	■	□	□
90	78	3.0 (76)	—	—	—	—	—	—	■	□
150	128	3.8 (96)	—	—	—	—	—	—	—	■

— not available ■ standard □ on request

WATER SEAL POT

For the protection of the actuator diaphragm, when used with steam, the reducer must be installed with water seal pot "SP40" placed on the downstream pressure signal connected to the actuator.

1. Upstream block valve
2. Upstream pressure gauge
3. RD10 pressure reducer
4. Reduced pressure pipe
5. Safety valve
6. Reducer pressure gauge
7. Downstream block valve
8. SP40 water seal pot
9. Filling pot

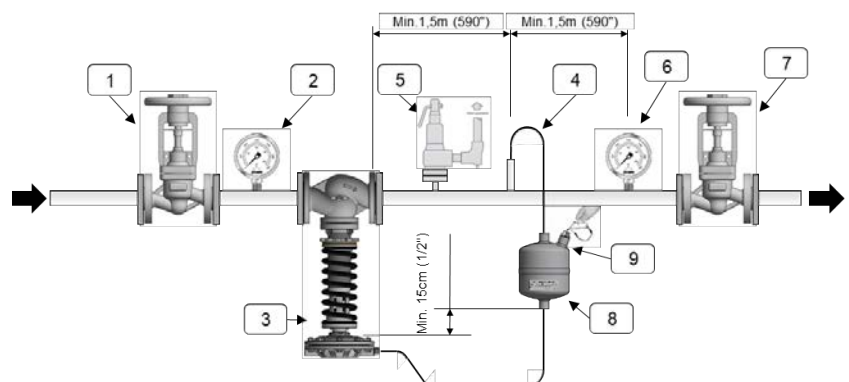

DIMENSIONS

SIZE	A inches (mm)		B inches (mm)	C inches (mm)					
				AR85	AR100	AR120	AR150	AR205	AR265
½"	7.5" (184)	7.46 (190)	16.0 (406)						
¾"	7.5" (184)	7.62 (194)	16.0 (406)						
1"	7.5" (184)	7.75 (197)	16.8 (425)						
1" ½	8.75" (222)	9.25 (235)	20.1 (510)	6.1 (155)	6.7 (170)	7.7 (195)	8.7 (220)	11.2 (283)	13.5 (343)
2"	10.00" (254)	10.50 (267)	20.1 (510)						
2" ½	10.86 (276)	11.49 (292)	21.7 (550)						
3"	11.75" (298.5)	12.50 (318)	21.5 (544)						
4"	13.88" (352.5)	14.50 (368)	26.4 (670)						

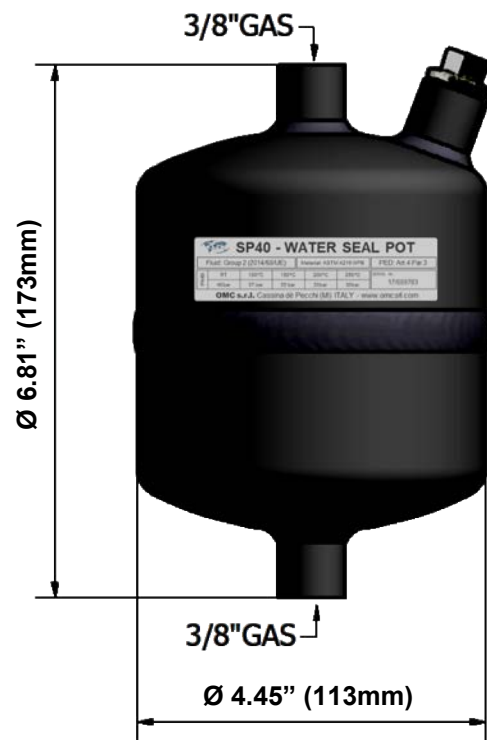

SP40
 Available on request
 WATER SEAL POT FOR USE ON
 STEAM
 PN40 - ASTM A216 WPB Material

AVAILABLE ENDS CONNECTIONS

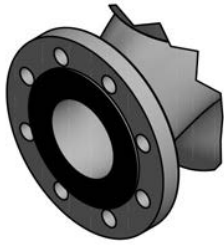

RAISED FACE



RING JOINT



MALE FACE



FEMALE FACE



FLAT FACE



BUTT-WELDING



SOCKET-WELDING



GROOVE FACE

REDUCER WEIGHT (Kg)

1/2"	9.5
3/4"	10.0
1"	11.0
1" 1/2	20.5
2"	23.0
2" 1/2	36.0
3"	39.5
4"	50.0

ACTUATOR WEIGHT (Kg)

AR085	4.5
AR100	5.0
AR120	7.5
AR150	8.5
AR205	14.5
AR265	20.5

The contents of this publication are presented for information purpose only. OMC reserve the modify or improve the designs or specifications of such products at any time without notice



OMC S.p.A.

Via Galileo Galilei, 18 - 20060
Cassina de Pecchi (MI) - ITALY
Tel.: (+39) 02.95.28.468
Fax: (+39) 02.95.21.495
info@omcvalves.com
www.omcvalves.com